

## Spec.Description Model : B13/B14/B15

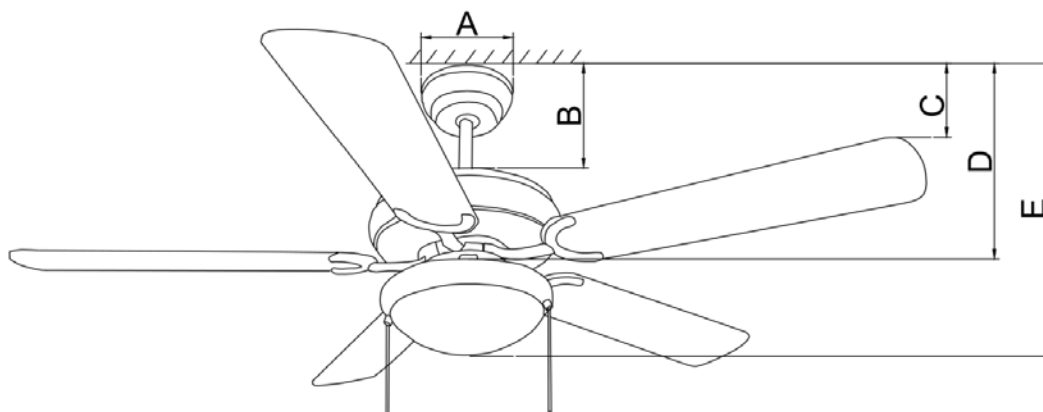

<b>TISI Model:</b> (安規代號)	WF552MP			<b>Fridgecode</b> 條碼	B13# 8858786400215 B14# 8858786400222 B15# 8858786400239	
<b>Code:</b> (型號)	B13/B14/B15			<b>Color:</b> (顏色)	B13# = 古銅(AB) B14# = 啞白(WHT) B15# = 啞黑 (MBK)	
<b>Specification</b> (規格)	52 inch/5 Blades /With 1 L			<b>Motor Size</b> 馬達規格	AC/153*18	
<b>Material</b> (材料)	Plywood			<b>Switch Category</b> 開關類別	Pull switch 拉繩開關	
<b>Speed</b> 轉速	<b>Current (A)</b> 安培	<b>Wattage (W)</b> 瓦特	<b>RPM</b> 轉速	<b>Air Flow (CFM)</b> 風量	<b>Efficiency</b> (CFM/Wattage)	
1 速	0.34	75	200	5000	66	
2 速	0.26	40	150	3000	75	
3 速	0.19	19	100	1800	94	
4 速	-	-	-	-	-	
5 速	-	-	-	-	-	
<b>Fan</b>	<b>A</b>	吊盅直徑			15	cm
	<b>B</b>	天花板到上罩高度			19	cm
	<b>C</b>	天花板到葉片高度			29.5	cm
	<b>D</b>	天花板到馬達底部高度			37.5	cm
	<b>E</b>	天花板到玻璃高度			45	cm
<b>Carton</b>	<b>L (長)</b>	55			cm	
	<b>W (寬)</b>	33.7			cm	
	<b>H (高)</b>	26			cm	
<b>Package</b>	<b>N.W(淨重)</b>	7.7			KGS	
	<b>G.W(毛重)</b>	8.55			KGS	