

## Spec.Description Model : SD01/SD03/SD15

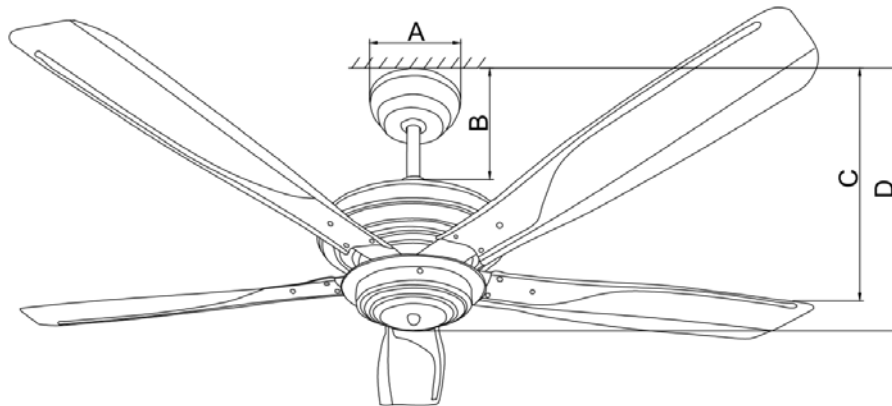

<b>TISI Model:</b> (安規代號)	WF556CP			<b>Fridgecode</b> 條碼	SD01# 8858786401533 SD03# 8858786401557 SD15# 8858786402516	
<b>Code:</b> (型號)	SD01/SD03/SD15			<b>Color:</b> (顏色)	SD01# = AB(古銅) SD03# = GM(珍珠黑) SD15# = S.S(砂石灰)	
<b>Specification</b> (規格)	56 inch/5 Blades /No L			<b>Motor Size</b> 馬達規格	AC/188*15	
<b>Material</b> (材料)	Steel (鐵葉)			<b>Switch Category</b> 開關類別	Infrared Remote Control <QF-R8-A (2.5+3 uF)>	
<b>Speed</b> 轉速	<b>Current (A)</b> 安培	<b>Wattage (W)</b> 瓦特	<b>RPM</b> 轉速	<b>Air Flow (CFM)</b> 風量	<b>Efficiency</b> ( CFM/Wattage)	
1 速	0.36	76	220	5200	68	
2 速	0.32	43	160	3105	72	
3 速	0.25	21	100	2000	95	
4 速	-	-	-	-	-	
5 速	-	-	-	-	-	
<b>Fan</b>	<b>A</b>	吊盅直徑			15	cm
	<b>B</b>	天花板到上罩高度			19	cm
	<b>C</b>	天花板到葉片高度			41.5	cm
	<b>D</b>	天花板到馬達底部高度			46.5	cm
	<b>E</b>	天花板到玻璃高度			-	cm
<b>Carton</b>	<b>L(長)</b>	64.2				cm
	<b>W(寬)</b>	36.4				cm
	<b>H(高)</b>	23.7				cm
<b>Package</b>	<b>N.W(淨重)</b>	9.31 KG				KGS
	<b>G.W(毛重)</b>	10.31 KG				KGS